



DEPARTMENT OF REGULATORY AND ECONOMIC RESOURCES (RER)
BOARD AND CODE ADMINISTRATION DIVISION

NOTICE OF ACCEPTANCE (NOA)

MIAMI-DADE COUNTY
PRODUCT CONTROL SECTION
11805 SW 26 Street, Room 208
Miami, Florida 33175-2474
T (786) 315-2590 F (786) 315-2599
www.miamidade.gov/economy

DAB Door Company, Inc.
12195 NW 98th Avenue
Hialeah Gardens, FL 33018

SCOPE:

This NOA is being issued under the applicable rules and regulations governing the use of construction materials. The documentation submitted has been reviewed and accepted by Miami-Dade County RER-Product Control Section to be used in Miami-Dade County and other areas where allowed by the Authority Having Jurisdiction (AHJ).

This NOA shall not be valid after the expiration date stated below. The Miami-Dade County Product Control Section (In Miami-Dade County) and/or the AHJ (in areas other than Miami-Dade County) reserve the right to have this product or material tested for quality assurance purposes. If this product or material fails to perform in the accepted manner, the manufacturer will incur the expense of such testing and the AHJ may immediately revoke, modify, or suspend the use of such product or material within their jurisdiction. RER reserves the right to revoke this acceptance, if it is determined by Miami-Dade County Product Control Section that this product or material fails to meet the requirements of the applicable building code.

This product is approved as described herein and has been designed to comply with the Florida Building Code, including the High Velocity Hurricane Zone.

DESCRIPTION: Hurricane Master Model 824/811 Steel Sectional Garage Door up to 16ft.-2in. w/ Window Lite Option (DP +27.0, -30.0 PSF)

APPROVAL DOCUMENT: Drawing No. **03-06**, titled "Sectional Garage Door", sheets 1, 1.1, 2 through 6 of 6, dated 09/30/2003, with revision **O** dated 06/19/2023, prepared by Al-Farooq Corporation, signed and sealed by Jalal Farooq, P.E., bearing the Miami-Dade County Product Control revision stamp with the Notice of Acceptance number and the expiration date by the Miami-Dade County Product Control Section.

MISSILE IMPACT RATING: Large and Small Missile Impact Resistant (without flood vents)

LABELING: A permanent label with the manufacturer's name or logo, manufacturing address, model number, the positive and negative design pressure rating, indicate impact rated if applicable, installation instruction drawing reference number, approval number (NOA), the applicable test standards, and the statement reading 'Miami-Dade County Product Control Approved' is to be located on the door's side track, bottom angle, or inner surface of a panel.

LIMITATION: Garage doors with flood vents are not rated for Large Missile Impact Resistance.

RENEWAL of this NOA shall be considered after a renewal application has been filed and there has been no change in the applicable building code negatively affecting the performance of this product.

TERMINATION of this NOA will occur after the expiration date or if there has been a revision or change in the materials, use, and/or manufacture of the product or process. Misuse of this NOA as an endorsement of any product, for sales, advertising or any other purposes shall automatically terminate this NOA. Failure to comply with any section of this NOA shall be cause for termination and removal of NOA.

ADVERTISEMENT: The NOA number preceded by the words Miami-Dade County, Florida, and followed by the expiration date may be displayed in advertising literature. If any portion of the NOA is displayed, then it shall be done in its entirety.

INSPECTION: A copy of this entire NOA shall be provided to the user by the manufacturer or its distributors and shall be available for inspection at the job site at the request of the Building Official.

This NOA **revises NOA #22-0816.04** and consists of this page 1 and evidence pages E-1, E-2, E-3, E-4, E-5 and E-6, as well as approval document mentioned above.

The submitted documentation was reviewed by **Helmy A. Makar, P.E., M.S.**



Handwritten signature: H.A. Makar
09/14/2023

NOA-No. 23-0710.20
Expiration Date: 08/14/2026
Approval Date: 09/14/2023

NOTICE OF ACCEPTANCE: EVIDENCE SUBMITTED

1. EVIDENCE SUBMITTED UNDER PRIVIOUS NOAs

A. DRAWINGS

1. Drawing No. **03-06**, titled "Sectional Garage Door", dated 09/30/2003, with last revision K dated 03/21/2016, sheets 1 through 5 of 5, prepared by Al-Farooq Corporation, signed and sealed by Javad Ahmad, P.E.

B. TESTS "*Submitted under NOA # 08-1106.05*"

1. Test reports on 1) Uniform Static Air Pressure Test, Loading per FBC TAS 202-94
2) Large Missile Impact Test per FBC, TAS 201-94
3) Cyclic Wind Pressure Loading per FBC, TAS 203-94
4) Forced Entry Test, per FBC 2411 3.2.1, TAS 202-94

Along with marked-up drawings and installation diagram of DAB 824 24ga sectional garage door, prepared by Hurricane Engineering & Testing, Inc., Test Report No. **HETI-08-2149A/B**, dated 06/27/2008, signed and sealed by Candido F. Font, P.E.

"Submitted under NOA # 05-0915.12"

2. Test Report on Large Missile Impact Test per FBC, TAS 201 and Cyclic Wind Pressure Test per FBC, TAS 203, of "Sectional Residential Door with Windows", prepared by Hurricane Engineering & Testing Inc., Report No. **HETI 03-1348A**, dated 09/29/2003, signed and sealed by Rafael E. Droz-Seda, P.E.
3. Test Report on Uniform Static Air Pressure Test per FBC, TAS 202, of "Sectional Residential Door" prepared by Hurricane Engineering & Testing Inc., Report No. **HETI 03-1337A**, dated 09/29/2003, signed and sealed by Rafael E. Droz-Seda, P.E.
4. Test Report on Tensile Test per ASTM E-8 of "Sectional Residential Door (skin)", prepared by Hurricane Engineering & Testing Inc, Report No. **HETI 03-T058**, dated 10/31/2003, signed and sealed by Rafael E. Droz-Seda, P.E.

"Submitted under NOA # 03-0210.04"

5. Test report on Salt Spray (Corrosion) Test per ASTM B 117 of a painted G-40 steel panels, prepared by Celotex Corporation, Test Report No. **258592**, dated 10/28/2003, signed by W. A. Jackson, P.E.

C. CALCULATIONS "*Submitted under NOA # 14-0814.07*"

1. Anchor verification calculations prepared by Al-Farooq Corporation, dated 09/22/2014 and 07/24/2014, signed and sealed by Javad Ahmad, P.E.



Helmy A. Makar, P.E., M.S.
Product Control Section Supervisor
NOA-No. 23-0710.20
Expiration Date: 08/14/2026
Approval Date: 09/14/2023

NOTICE OF ACCEPTANCE: EVIDENCE SUBMITTED

C. CALCULATIONS (Cont.)

“Submitted under NOA # 09-0324.06”

2. Anchor verification calculations prepared by Al-Farooq Corporation, complying with F.B.C 2007, dated 01/20/2009, signed and sealed by Humayoun Farooq, P.E.

D. QUALITY ASSURANCE

1. Miami-Dade Department of Regulatory and Economic Resources (RER).

E. MATERIAL CERTIFICATIONS

1. Notice of Acceptance No. **15-0915.08**, issued to SABIC Innovative Plastics, for their Lexan Polycarbonate Sheet Products, approved on 12/10/2015 and expiring on 07/17/2018.
2. Notice of Acceptance No. **14-0311.08**, issued to Insulfoam, LLC, for their Insulfoam Expanded Polystyrene Insulation, approved on 08/14/2014 and expiring on 11/29/2017.
3. Notice of Acceptance No. **11-0926.07**, issued to Dyplast Products, LLC, for their Expanded Polystyrene Block Type Insulation, approved on 11/10/2011 and expiring on 01/11/2017.
4. Notice of Acceptance No. **11-0926.06**, issued to Dyplast Products, LLC, for their Dyplast ISO-C1 Polyisocyanurate Insulation, approved on 11/10/2011 and expiring on 01/11/2017.
5. Notice of Acceptance No. **15-1203.04**, issued to Cellofoam North America Inc, for their Expanded Polystyrene Block Insulation, approved on 03/17/2016 and expiring on 02/24/2021.

“Submitted under NOA # 05-0228.02”

6. Test Report on Accelerated Weathering Using Xenon Arc Light Apparatus Test per ASTM G155 of “PVC Extrusion Material”, prepared by Hurricane Engineering & Testing, Inc., Report No. **HETI 04-A002**, dated 09/27/2004, signed and sealed by Rafael E. Droz-Seda, P.E.
7. Test Reports on Tensile Test per ASTM D638 of “PVC Extrusion Material”, prepared by Hurricane Engineering & Testing Inc., Report No. **HETI 04-T251**, dated 11/29/2004 signed and sealed by I. Ghia, P.E.
8. Test Report on Self-Ignition Temperature Test, Rate of Burn Test and Smoke Density Test of “REHAU non-foam PVC extrusion material”, prepared by ETC Laboratories, Report No. **04-761-15019.0**, dated 05/06/2004, signed and sealed by J. L. Doldan, P.E.

F. STATEMENTS

1. Statement letter of code conformance to the 5th edition (2014) FBC and no financial interest issued by Al-Farooq Corporation, dated 03/21/2016, signed and sealed by Javad Ahmad, P.E.



Helmy A. Makar, P.E., M.S.
Product Control Section Supervisor
NOA-No. 23-0710.20
Expiration Date: 08/14/2026
Approval Date: 09/14/2023

NOTICE OF ACCEPTANCE: EVIDENCE SUBMITTED

2. EVIDENCE SUBMITTED UNDER NOA # 17-0919.12

A. DRAWINGS

1. Drawing No. **03-06 Rev. L**, titled "Sectional Garage Door", dated 09/30/2003 and last revised on AUG 17, 2017, sheets 1, 1.1, 2 through 5 of 5, prepared by Al-Farooq Corporation, signed and sealed by Javad Ahmad, P.E.

Note: This revision consists of editorial changes to comply with FBC 2017.

B. CALCULATIONS

1. None.

C. QUALITY ASSURANCE

1. Miami Dade Department of Regulatory and Economic Resources (RER).

D. MATERIAL CERTIFICATIONS

1. Notice of Acceptance No. **17-0221.06**, issued to Insulfoam, LLC, for their Insulfoam Expanded Polystyrene Insulation, expiring on 11/29/2022.
2. Notice of Acceptance No. **16-1108.04**, issued to Dyplast Products, LLC, for their Dyplast ISO-C1 Polyisocyanurate Insulation, expiring on 01/11/2022.
3. Notice of Acceptance No. **15-1203.04**, issued to Cellofoam North America Inc, for their Expanded Polystyrene Block Insulation, expiring on 02/24/2021.
4. Notice of Acceptance No. **15-0915.08**, issued to SABIC Innovative Plastics, for their Lexan Sheet Products, expiring on 07/17/2018.

E. STATEMENTS

1. Statement letter of conformance to FBC 2014 (5th Edition) and FBC 2017 (6th Edition), prepared by Al Farooq Corporation, dated 08/17/17, signed and sealed by Javad Ahmad, P.E.

F. OTHER

1. This NOA revises NOA #**16-0330.03**, expiring 08/14/21.



Helmy A. Makar, P.E., M.S.
Product Control Section Supervisor
NOA-No. 23-0710.20
Expiration Date: 08/14/2026
Approval Date: 09/14/2023

NOTICE OF ACCEPTANCE: EVIDENCE SUBMITTED

3. EVIDENCE SUBMITTED UNDER NOA # 21-0312.02

A. DRAWINGS

1. Drawing No. **03-06**, titled "Sectional Garage Door", dated 09/30/2003 and last revised on 07/21/2020, sheets 1, 1.1, 2 through 5 of 5, prepared by Al-Farooq Corporation, dated 08/21/2020, signed and sealed by Jalal Farooq, P.E.

B. TESTS

1. None.

C. CALCULATIONS

1. None.

D. QUALITY ASSURANCE

1. Miami Dade Department of Regulatory and Economic Resources (RER).

E. MATERIAL CERTIFICATIONS

1. Notice of Acceptance No. **19-0129.06**, issued to Insulfoam, LLC, for their Insulfoam Expanded Polystyrene Preformed Block Type I Insulation, expiring on 11/29/2022.
2. Notice of Acceptance No. **17-1207.04**, issued to Dyplast Products, LLC, for their Dyplast ISO-C1 Polyisocyanurate Rigid Foam Insulation, expiring on 01/11/2022.
3. Notice of Acceptance No. **18-0918.06**, issued to Plaskolite, LLC, for their TUFFAK Polycarbonate Sheets, approved on 01/15/2018 and expiring on 8/27/2022.

F. STATEMENTS

1. Testing contract letter issued by Hurricane Engineering & Testing Inc., dated 06/15/2021 and signed by Syed Waqar Ali, Ph.D.
2. Letter of conformance to FBC 2020 (7th Edition) and FBC 2017 (6th Edition), prepared by Al Farooq Corporation, dated 07/15/2020, signed and sealed by Jalal Farooq, P.E.



Helmy A. Makar, P.E., M.S.
Product Control Section Supervisor
NOA-No. 23-0710.20
Expiration Date: 08/14/2026
Approval Date: 09/14/2023

NOTICE OF ACCEPTANCE: EVIDENCE SUBMITTED

4. EVIDENCE SUBMITTED UNDER NOA # 22-0816.04

A. DRAWINGS

1. Drawing No. **01-05**, titled "Sectional Garage Door", sheets 1, 1.1, 2 through 6 of 6, dated 09/30/2003, with revision N dated 08/12/2022, prepared by Al-Farooq Corporation, signed and sealed by Jalal Farooq, P.E.

B. TESTS

1. Test reports on
 - 1) Uniform Static Air Pressure Test Loading per FBC TAS 202-94
 - 2) Large Missile Impact Test per FBC, TAS 201-94
 - 3) Cyclic Wind Pressure Loading per FBC, TAS 203-94
 - 4) Forced Entry Test per FBC, TAS 202-94along with marked-up drawings and installation diagram of a DAB 824/811, 24 GA, 16'-2" wide x 8' high Sectional Garage Door with Fixed Windows, prepared by Hurricane Engineering & Testing, Inc, Test Reports No. **HETI-22-7201**, dated 08/11/2022, signed and sealed by Ram N. Tewari, P.E.
2. Test report of Tensile Test per ASTM E 8, Report No. **HETI 22-T595**, prepared by Hurricane Engineering & Testing, Inc., dated 08/01/2022, signed and sealed by Ram N. Tewari, P.E.

C. CALCULATIONS

1. None.

D. QUALITY ASSURANCE

1. Miami Dade Department of Regulatory and Economic Resources (RER).

E. MATERIAL CERTIFICATIONS

1. Notice of Acceptance No. **22-0628.11**, issued to Insulfoam, a div. of Carlisle Const. Mat., LLC, for their Insulfoam Expanded Polystyrene Preformed Block Type I Insulation, expiring on 11/29/2023.
2. Notice of Acceptance No. **22-0627.03**, issued to Kingspan Insulation LLC, for their ISO-C1 Polyisocyanurate Rigid Foam Insulation, expiring on 01/11/2027.
3. Notice of Acceptance No. **22-0317.02**, issued to Plaskolite, LLC, for their TUFFAK Polycarbonate Sheets, expiring on 8/27/2027.
4. Notice of Acceptance No. **21-0222.05**, issued to Cellofoam North America Inc., for their Expanded Polystyrene Block Insulation, expiring 02/24/2026.

F. STATEMENTS

1. Statement letter of code conformance to 7th Edition (2020) of the FBC and of no financial interest, prepared by Al Farooq Corporation, dated 08/12/2022, signed and sealed by Jalal Farooq, P.E.

NOTICE OF ACCEPTANCE: EVIDENCE SUBMITTED

5. NEW EVIDENCE SUBMITTED

A. DRAWINGS

1. Drawing No. **01-05**, titled "Sectional Garage Door", sheets 1, 1.1, 2 through 6 of 6, dated 09/30/2003, with revision N dated 08/12/2022, prepared by Al-Farooq Corporation, signed and sealed by Jalal Farooq, P.E.

B. TESTS

1. None.

C. CALCULATIONS

1. None.

D. QUALITY ASSURANCE

1. Miami Dade Department of Regulatory and Economic Resources (RER).

E. MATERIAL CERTIFICATIONS

1. Notice of Acceptance No. **22-0628.11**, issued to Insulfoam, a div. of Carlisle Const. Mat., LLC, for their Insulfoam Expanded Polystyrene Preformed Block Type I Insulation, expiring on 11/29/2023.
2. Notice of Acceptance No. **22-0627.03**, issued to Kingspan Insulation LLC, for their ISO-C1 Polyisocyanurate Rigid Foam Insulation, expiring on 01/11/2027.
3. Notice of Acceptance No. **22-0317.02**, issued to Plaskolite, LLC, for their TUFFAK Polycarbonate Sheets, expiring on 8/27/2027.
4. Notice of Acceptance No. **21-0222.05**, issued to Cellofoam North America Inc., for their Expanded Polystyrene Block Insulation, expiring 02/24/2026.

F. STATEMENTS

1. Statement letter of code conformance to 7th Edition (2020) and 8th Edition (2023) of the FBC and of no financial interest, prepared by Al Farooq Corporation, dated 06/21/2023, signed and sealed by Jalal Farooq, P.E.



Helmy A. Makar, P.E., M.S.
Product Control Section Supervisor
NOA-No. 23-0710.20
Expiration Date: 08/14/2026
Approval Date: 09/14/2023

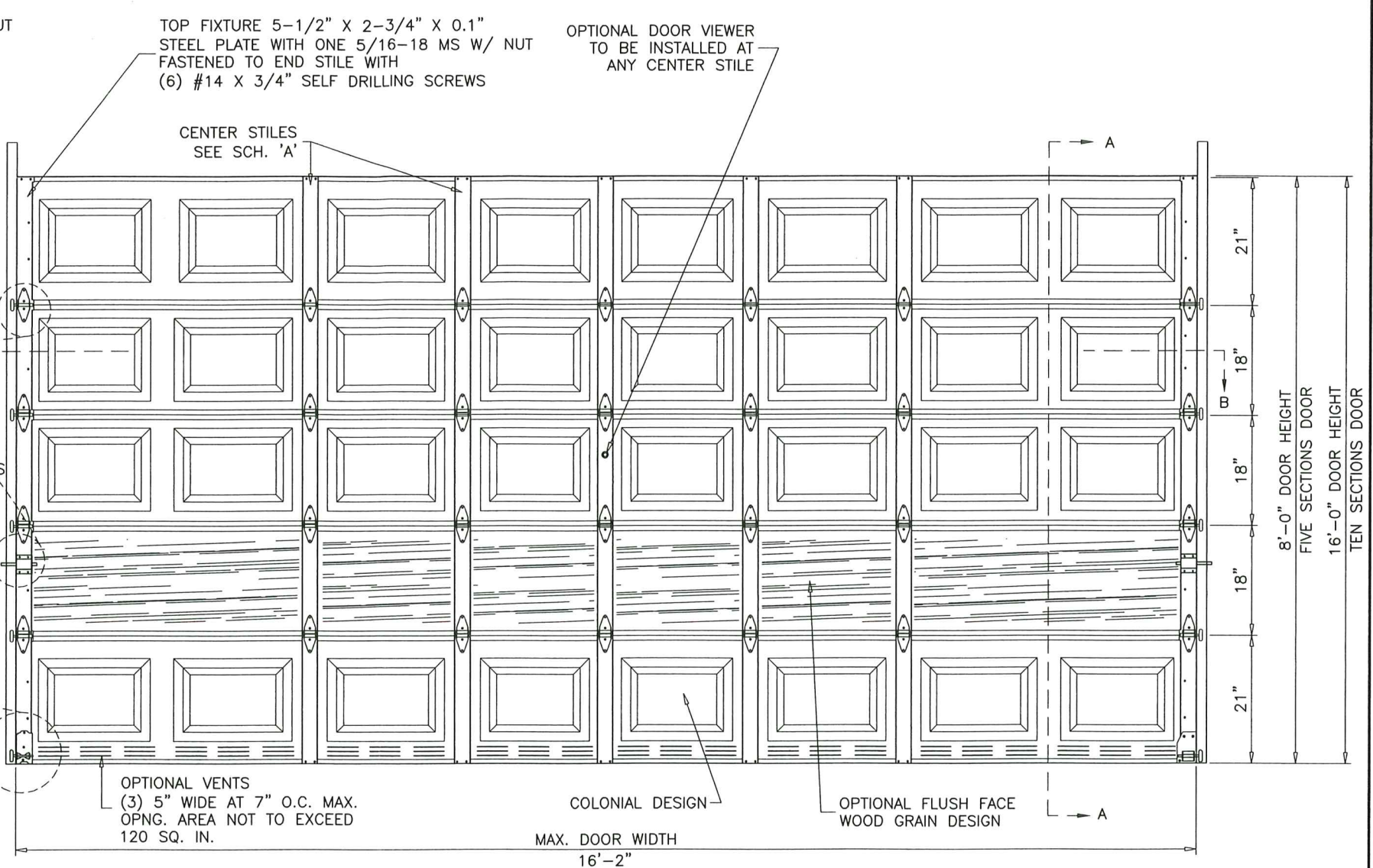
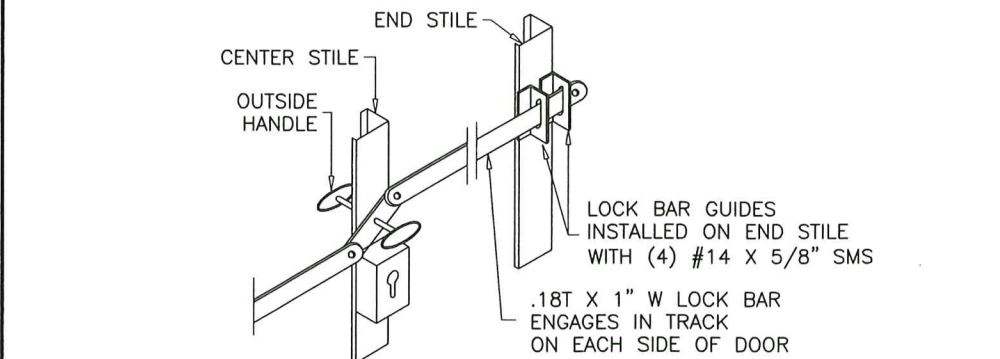
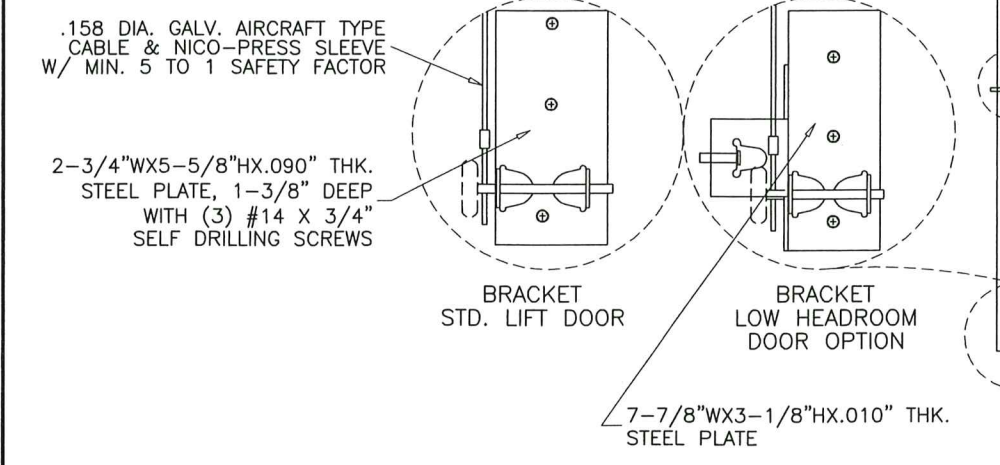
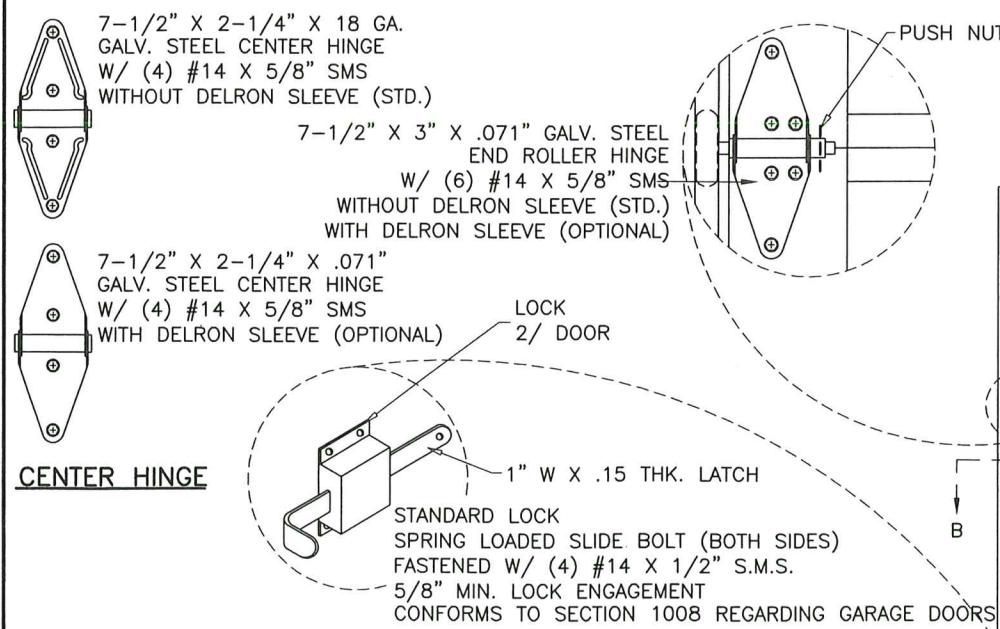

INSIDE ELEVATION
RAISED PANEL EMBOSSED DOOR

#14 X 3/4" SELF DRILLING SCREWS MAY BE USED IN LIEU OF #14 X 5/8" SMS

PRODUCT REVISED
as complying with the Florida Building Code
Acceptance No 23-0710.20
Expiration Date 08/14/2026
By *Helga M. M...*
Miami Dade Product Control

DESIGN PRESSURE RATING = + 27.0 PSF
- 30.0 PSF

DAB DOOR INC.
Hurricane Master® Model 824/811
Max. Size 16'-2" X 16'-0" High
With Window Lite Option

THIS PRODUCT IS RATED FOR LARGE MISSILE IMPACT

DOOR TESTED IN ACCORDANCE WITH THE REQUIREMENTS OF FLORIDA BUILDING CODE, TAS-202, TAS-201 & TAS-203 FOR HVHZ AND ASTM E1886-05/ASTM E1996-09.

GENERAL NOTES

1. THIS PRODUCT HAS BEEN DESIGNED AND TESTED TO COMPLY WITH THE REQUIREMENTS OF THE 2020 (7TH EDITION)/2023 (8TH EDITION) FLORIDA BUILDING CODE INCLUDING HIGH VELOCITY HURRICANE ZONE (HVHZ).
2. ANCHORS SHALL BE CORROSION RESISTANT, SPACED AS SHOWN ON DETAILS AND INSTALLED PER MANUF'S INSTRUCTIONS. SPECIFIED EMBEDMENT TO BASE MATERIAL SHALL BE BEYOND WALL DRESSING OR STUCCO.
3. A LOAD DURATION INCREASE IS USED IN DESIGN OF ANCHORS INTO WOOD ONLY.
4. MATERIALS INCLUDING BUT NOT LIMITED TO STEEL/METAL SCREWS, THAT COME INTO CONTACT WITH OTHER DISSIMILAR MATERIALS SHALL MEET THE REQUIREMENTS OF THE 2020/2023 FLORIDA BLDG. CODE & ADOPTED STANDARDS.
5. THIS PRODUCT APPROVAL IS GENERIC AND DOES NOT PROVIDE INFORMATION FOR A SITE SPECIFIC PROJECT, I.E. LIFE SAFETY OF THIS PRODUCT, ADEQUACY OF STRUCTURE RECEIVING THIS PRODUCT AND SEALING AROUND OPENING FOR WATER INFILTRATION RESISTANCE ETC. CONDITIONS NOT SHOWN IN THIS DRAWING ARE TO BE ANALYZED SEPARATELY, AND TO BE REVIEWED BY BUILDING OFFICIAL.
6. MANUFACTURER'S LABEL SHALL BE LOCATED ON A READILY VISIBLE LOCATION IN ACCORDANCE WITH SECTION 1709.9.3 OF FLORIDA BUILDING CODE. LABELING TO COMPLY WITH SECTION 1709.9.2.

JUN 22 2023

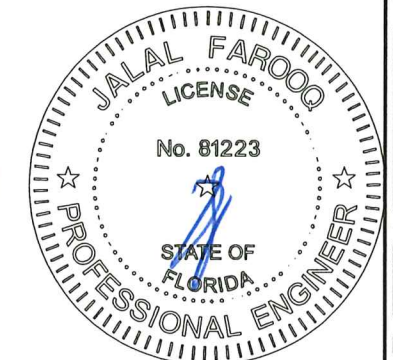

af c
AL-FAROOQ CORPORATION
ENGINEERS & PRODUCT DEVELOPMENT
9360 SUNSET DRIVE, SUITE 220
MIAMI, FLORIDA 33173 (C.A.N. 3538)
TEL. (305) 264-8100 FAX. (305) 264-8100 GARAGE\03-06DAB

SECTIONAL GARAGE DOOR
DAB Door Company, Inc.
12193 N.W. 98th Ave.
Hialeah Gardens, Fl. 33018
Tel: (800) 257-2016 Fax: (305) 362-9272

no	date	by	description
L	08.02.17		UPDATED TO 2017 FBC
M	07.21.20		UPDATED TO 2020 FBC
N	08.12.22		GENERAL REVISION
O	06.19.23		UPDATED TO 2023 FBC

date: 09-30-03
scale: 1/2"=1'-0"
dr. by: TARIQ
chk. by:

drawing no. **03-06**
sheet 1 of 6

DOOR HEIGHT	CONSISTS OF	
6'-6"	2 SECTIONS 18"	2 SECTIONS 21"
6'-9"	1 SECTION 18"	3 SECTIONS 21"
7'	4 SECTIONS 21"	-
7'-3"	-	-
7'-6"	5 SECTIONS 18"	-
7'-9"	4 SECTIONS 18"	1 SECTION 21"
8'	3 SECTIONS 18"	2 SECTIONS 21"
8'-3"	2 SECTIONS 18"	3 SECTIONS 21"
8'-6"	1 SECTION 18"	4 SECTIONS 21"
8'-9"	5 SECTIONS 21"	-
9'	6 SECTIONS 18"	-
9'-3"	5 SECTIONS 18"	1 SECTION 21"
9'-6"	4 SECTIONS 18"	2 SECTIONS 21"
9'-9"	3 SECTIONS 18"	3 SECTIONS 21"
10'	2 SECTIONS 18"	4 SECTIONS 21"
10'-3"	1 SECTION 18"	5 SECTIONS 21"
10'-6"	6 SECTIONS 21"	-
10'-9"	6 SECTIONS 18"	1 SECTION 21"
11'	5 SECTIONS 18"	2 SECTIONS 21"
11'-3"	4 SECTIONS 18"	3 SECTIONS 21"
11'-6"	3 SECTIONS 18"	4 SECTIONS 21"
11'-9"	2 SECTIONS 18"	5 SECTIONS 21"
12'	1 SECTIONS 18"	6 SECTIONS 21"
12'-3"	7 SECTIONS 21"	-
12'-6"	6 SECTIONS 18"	2 SECTIONS 21"
12'-9"	5 SECTIONS 18"	3 SECTIONS 21"
13'	4 SECTIONS 18"	4 SECTIONS 21"
13'-3"	3 SECTIONS 18"	5 SECTIONS 21"
13'-6"	2 SECTIONS 18"	6 SECTIONS 21"
13'-9"	1 SECTION 18"	7 SECTIONS 21"
14'	8 SECTIONS 21"	-
14'-3"	6 SECTIONS 18"	3 SECTIONS 21"
14'-6"	5 SECTIONS 18"	4 SECTIONS 21"
14'-9"	4 SECTIONS 18"	5 SECTIONS 21"
15'	3 SECTIONS 18"	6 SECTIONS 21"
15'-3"	2 SECTIONS 18"	7 SECTIONS 21"
15'-6"	1 SECTION 18"	8 SECTIONS 21"
15'-9"	9 SECTIONS 21"	-
16'	6 SECTIONS 18"	4 SECTIONS 21"

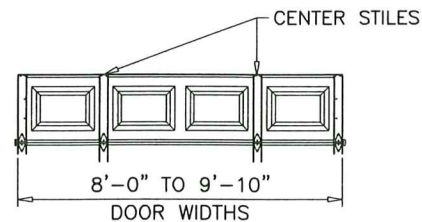

SCHEDULE 'A'

CENTER STILES CONFIGURATION	
DOOR WIDTHS	# OF CENTER STILES
8'-0" TO 9'-10"	2
10'-0" TO 11'-10"	2
12'-0" TO 13'-10"	3
14'-0" TO 15'-10"	4
15'-11" TO 16'-2"	5

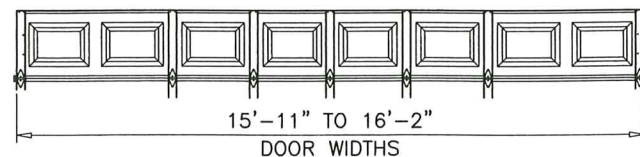
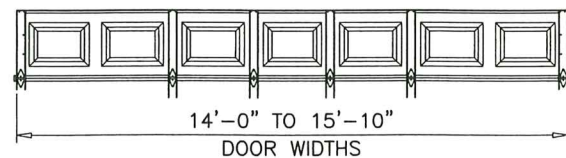
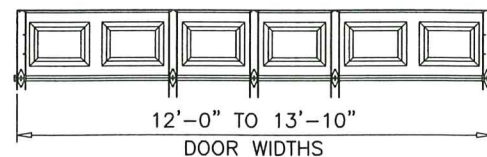
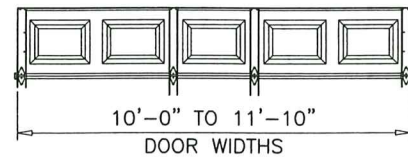

PRODUCT REVISED
as complying with the Florida
Building Code 23-0710-20
Acceptance No
Expiration Date 14 AUG 2026
By *Hedy A. Nasser*
Miami Dade Product Control

JUN 22 2023

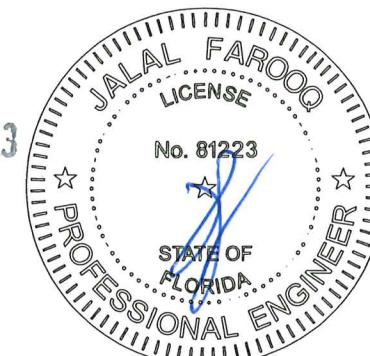

afc
AL-FAROOQ CORPORATION
ENGINEERS & PRODUCT DEVELOPMENT
9360 SUNSET DRIVE, SUITE 220
MIAMI, FLORIDA 33173 (C.A.N. 3538)
TEL. (305) 264-8100 FAX. (305) 262-6978
GARAGE\03-06DAB

SECTIONAL GARAGE DOOR
DAB Door Company, Inc.
12193 N.W. 98th Ave.
Hialeah Gardens, Fl. 33018
Tel: (800) 257-2016 Fax: (305) 362-9272

no	date	by	description
L	08.02.17		UPDATED TO 2017 FBC
M	07.21.20		UPDATED TO 2020 FBC
N	08.12.22		GENERAL REVISION
O	06.19.23		NO CHANGE THIS SHEET

date: 09-30-03
scale: 1/2"=1'-0"
dr. by: TARIQ
chk. by:
drawing no.
03-06
sheet 1.1 of 6

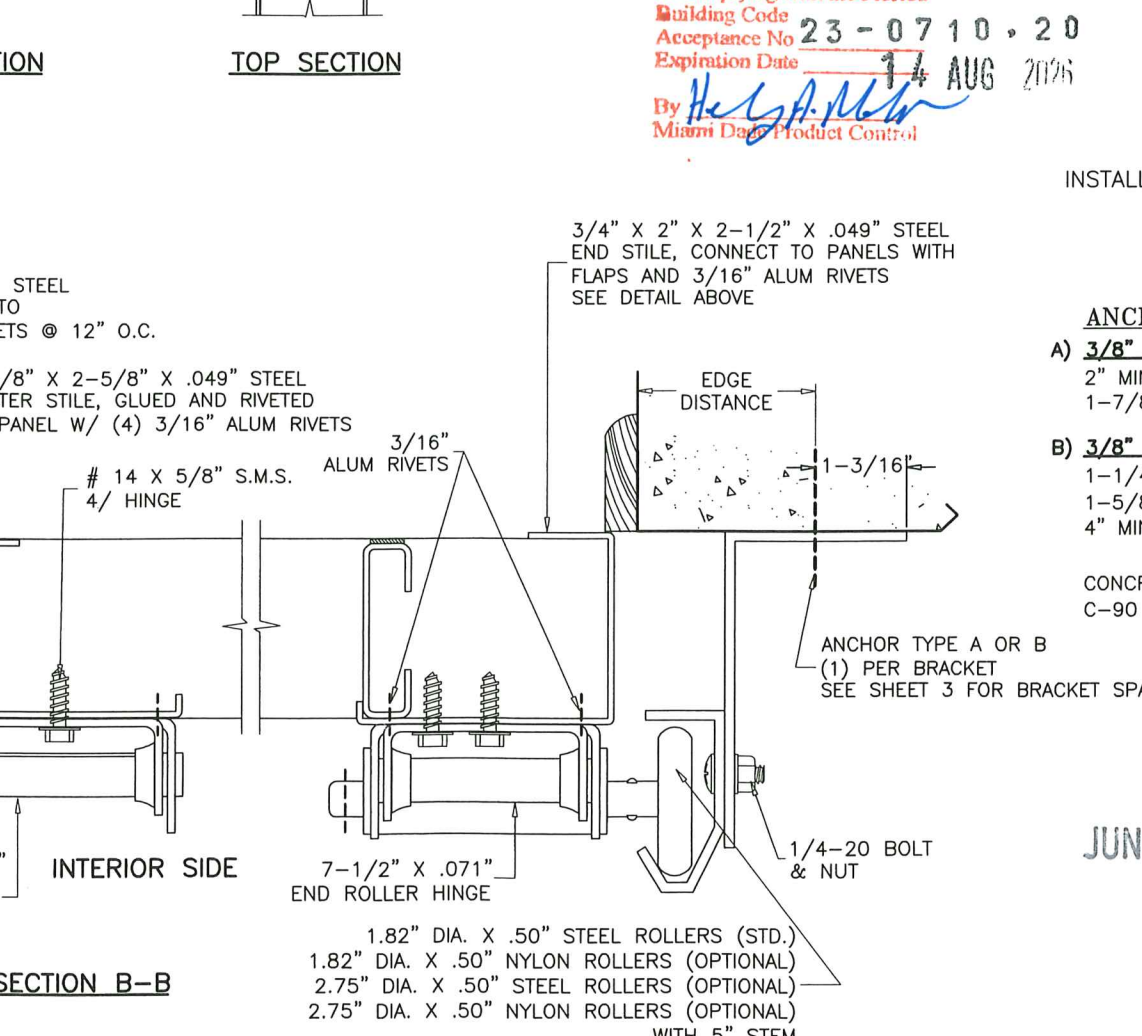
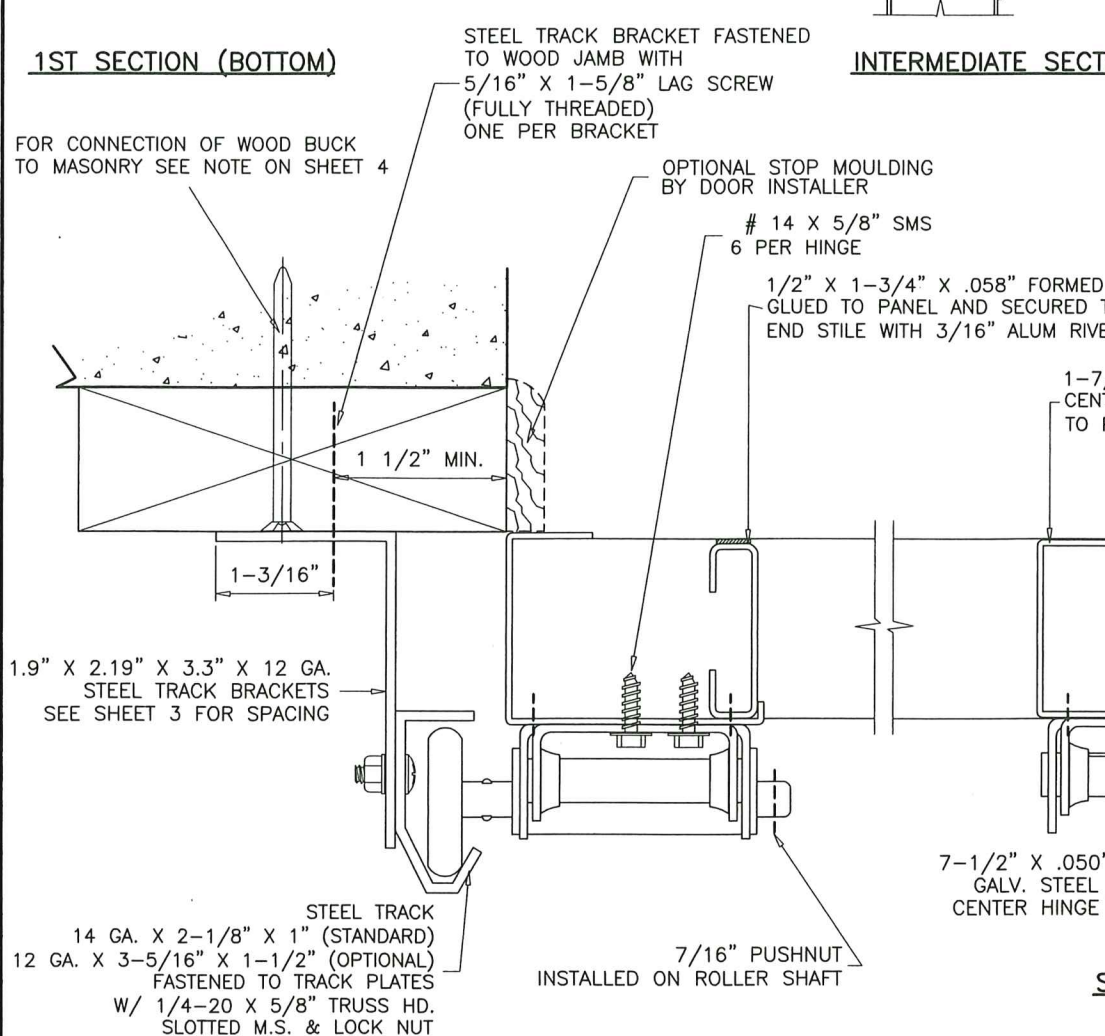
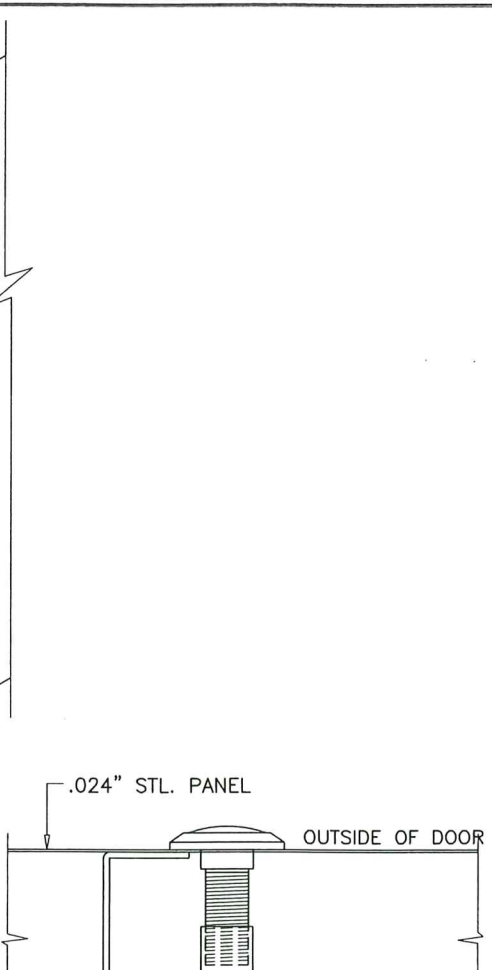
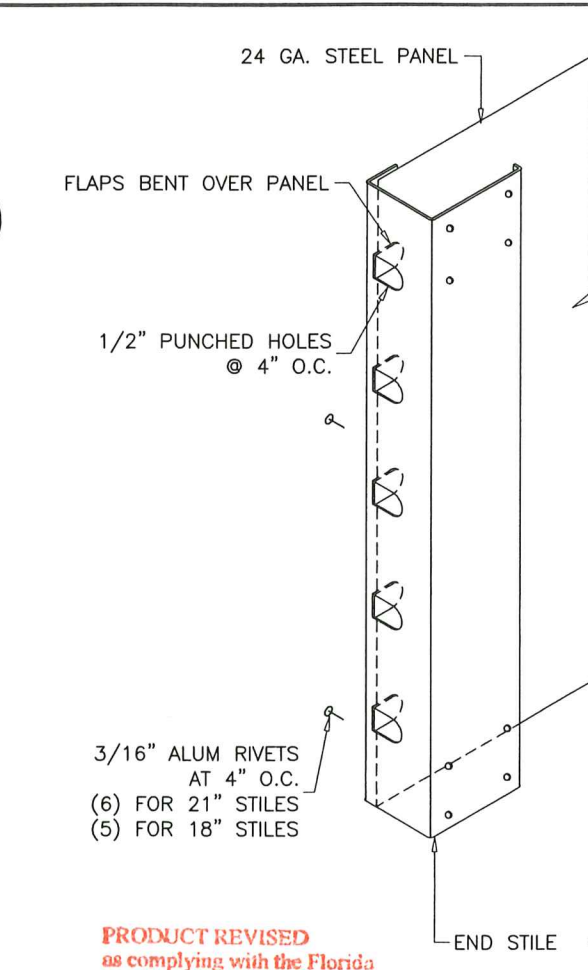
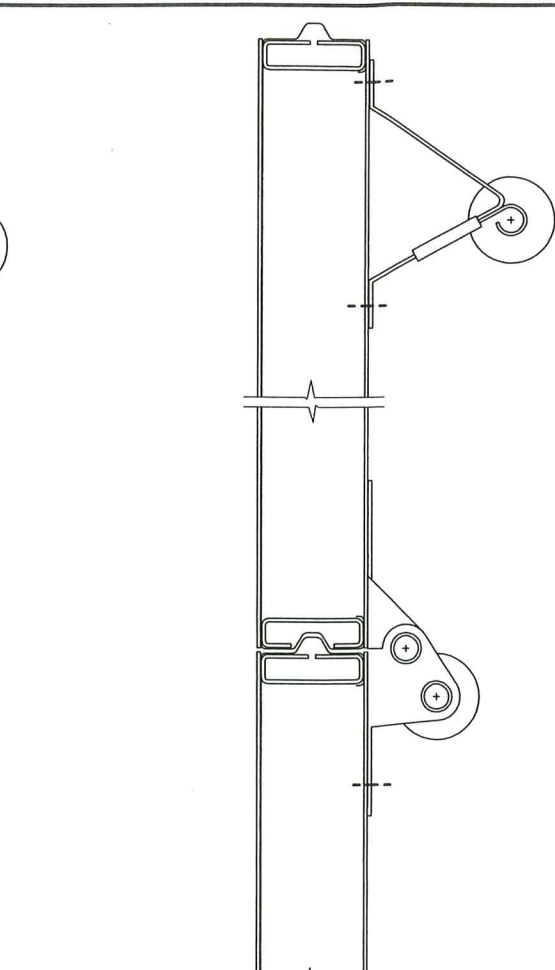
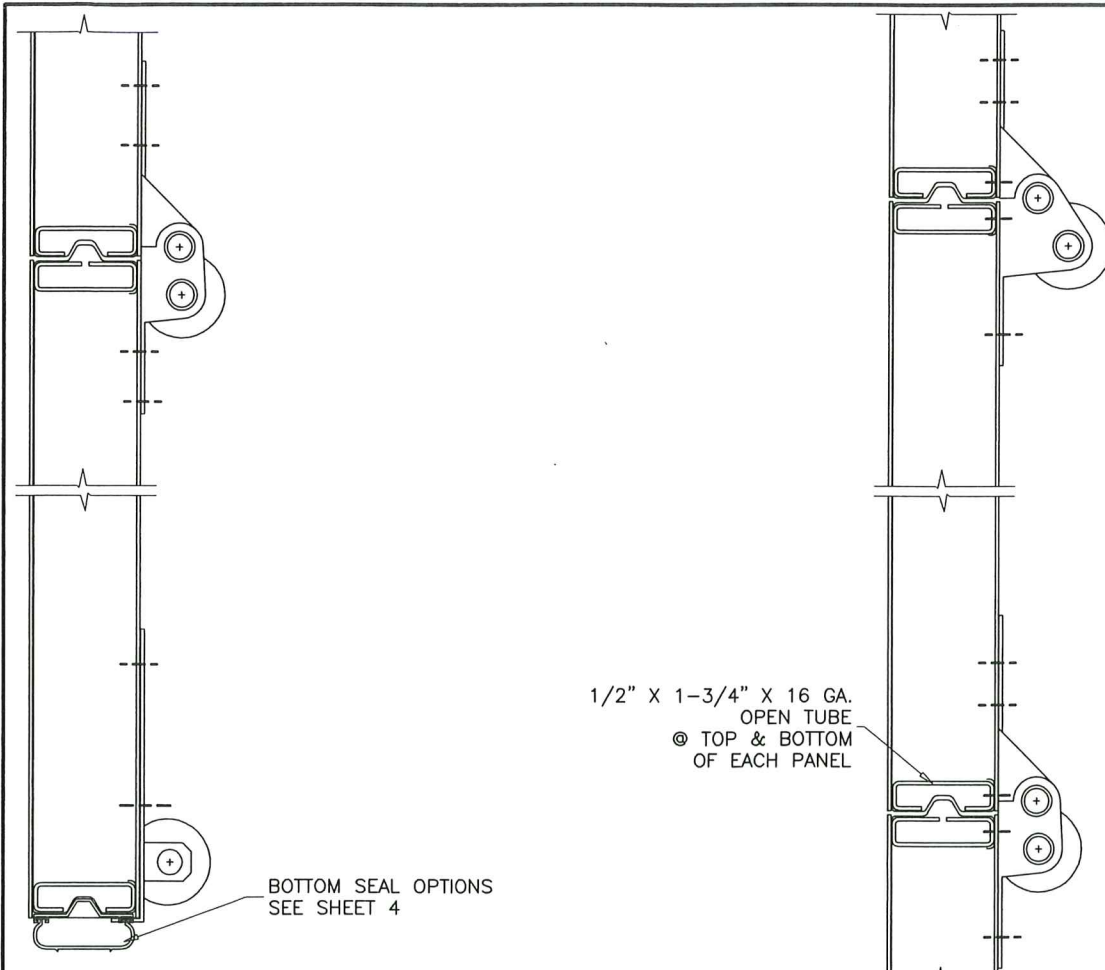

ANCHORS AT TRACK BRACKET:

A) 3/8" DIA. POWER-BOLT BY 'DEWALT'
2" MIN. EMBED INTO CONCRETE
1-7/8" MIN. EDGE DISTANCE

B) 3/8" DIA. HLC SLEEVE BY 'HILTI'
1-1/4" MIN. EMBED INTO CONCRETE OR FILLED BLOCK
1-5/8" MIN. EDGE DISTANCE INTO CONCRETE
4" MIN. EDGE DISTANCE INTO FILLED BLOCK

CONCRETE f'c = 3000 PSI MIN.
C-90 GROUT FILLED BLOCK f'm = 2000 PSI MIN.

JUN 22 2023

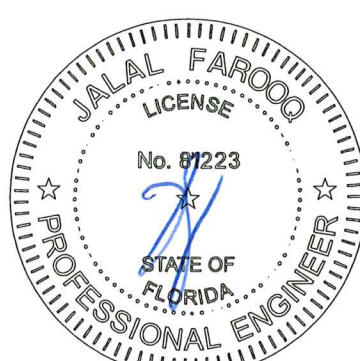

af c

AL-FAROOQ CORPORATION
ENGINEERS & PRODUCT DEVELOPMENT
9360 SUNSET DRIVE, SUITE 220
MIAMI, FLORIDA 33173 (C.A.N. 3538)
TEL. (305) 264-8100 FAX. (305) 262-6978

SECTIONAL GARAGE DOOR

DAB Door Company, Inc.
12193 N.W. 98th Ave.
Hialeah Gardens, FL 33018
Tel: (800) 257-2016 Fax: (305) 362-9272

no.	date	by	description
L	08.02.17		UPDATED TO 2017 FBC
M	07.21.20		UPDATED TO 2020 FBC
N	08.12.22		GENERAL REVISION
O	06.19.23		NO CHANGE THIS SHEET

date: 09-30-03
scale: -
dr. by: TARIQ
chk. by:

drawing no. 03-06
sheet 2 of 6

GARAGE\03-06DAB

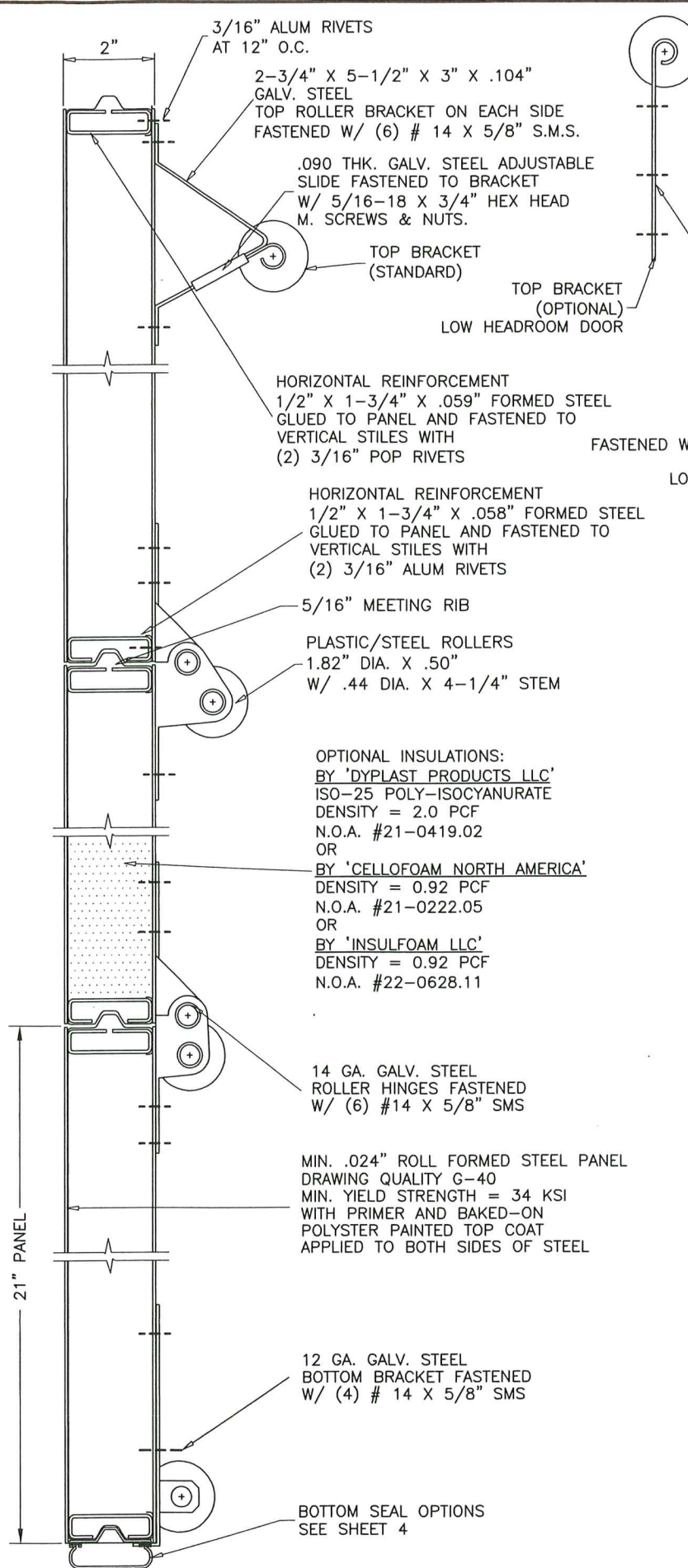

5/16" X 1-5/8" LAG SCREWS INTO WOOD OR 5/16" SLEEVE ANCHORS WITH 1-1/4" EMBED INTO MASONRY 3 PER BRACKET

2-1/2" X 4-1/4" X 13 GA. STEEL PLATES WELDED TO 1-1/2" X 1-1/2" X 14 GA. ANGLE FASTENED TO TRACK WITH (4) 1/4-20 BOLT & NUTS

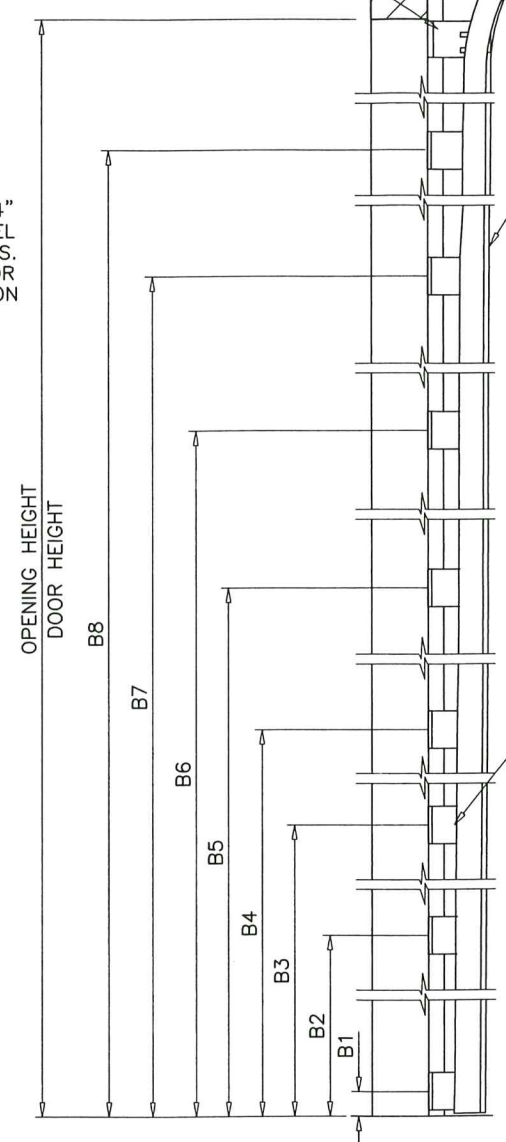

DOOR HEIGHT	* SECTION HEIGHTS					BRACKET PLACEMENTS							
	1ST	2ND	3RD	4TH	5TH	B1	B2	B3	B4	B5	B6	B7	B8
6'-0"	18"	18"	18"	18"	N/A	1" TO 2"	11-3/4"	23"	34"	45"	56"	67"	-
6'-6"	21"	18"	18"	21"	N/A	1" TO 2"	11-3/4"	23"	34"	45"	56"	67"	-
7'-0"	21"	21"	21"	21"	N/A	1" TO 2"	11-3/4"	23"	34"	45"	56"	67"	-
7'-6"	18"	18"	18"	18"	18"	1" TO 2"	11-3/4"	23"	34"	45"	56"	67"	78-1/4"
8'-0"	21"	18"	18"	18"	21"	1" TO 2"	11-3/4"	23"	34"	45"	56"	67"	78-1/4"

*-SECTIONS ARE NUMBERED STARTING AT THE BOTTOM FOR DOORS MORE THAN 8 FT. HIGH, USE ADDITIONAL TRACK BRACKETS AT 10" O.C.

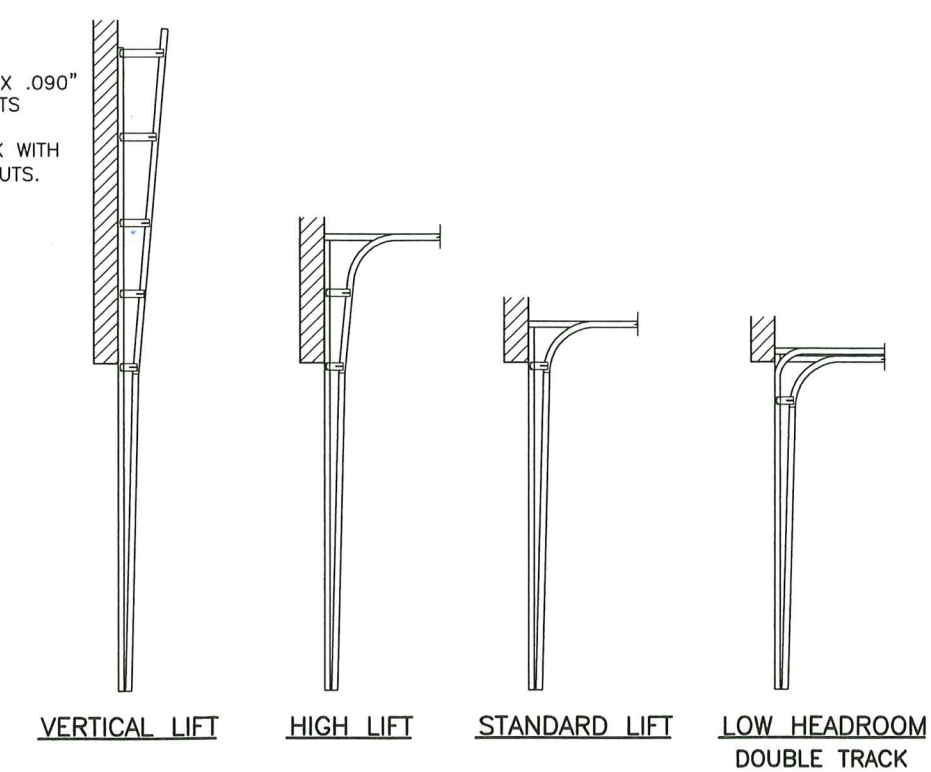

AVAILABLE TRACK OPTIONS

SECTION A-A
SEE SHEET 2 FOR LOCATION OF REINFORCING TRUSSES

PRODUCT REVISED as complying with the Florida Building Code
 Acceptance No. 23-0710-20
 Expiration Date 14 AUG 2026
 By *H. G. Anderson*
 Miami Dade Product Control

JUN 22 2023

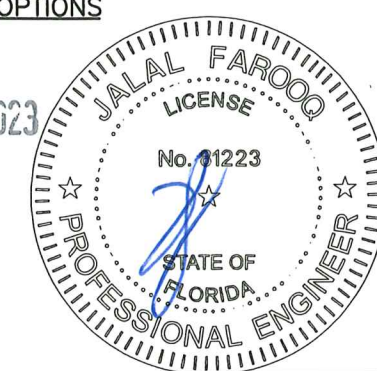

AL-FAROOQ CORPORATION
 ENGINEERS & PRODUCT DEVELOPMENT
 9360 SUNSET DRIVE, SUITE 220
 MIAMI, FLORIDA 33173
 TEL. (305) 264-8100 FAX. (305) 262-6978
 (C.A.N. 3538)

SECTIONAL GARAGE DOOR
DAB Door Company, Inc.
 12193 N.W. 98th Ave.
 Hialeah Gardens, Fl. 33018
 Tel: (800) 257-2016 Fax: (305) 362-9272

no	date	description
L	08.02.17	UPDATED TO 2017 FBC
M	07.21.20	UPDATED TO 2020 FBC
N	08.12.22	GENERAL REVISION
O	06.19.23	NO CHANGE THIS SHEET

date: 09-30-03
 scale: -
 dr. by: TARIQ
 chk. by:

drawing no.
03-06
 sheet 3 of 6

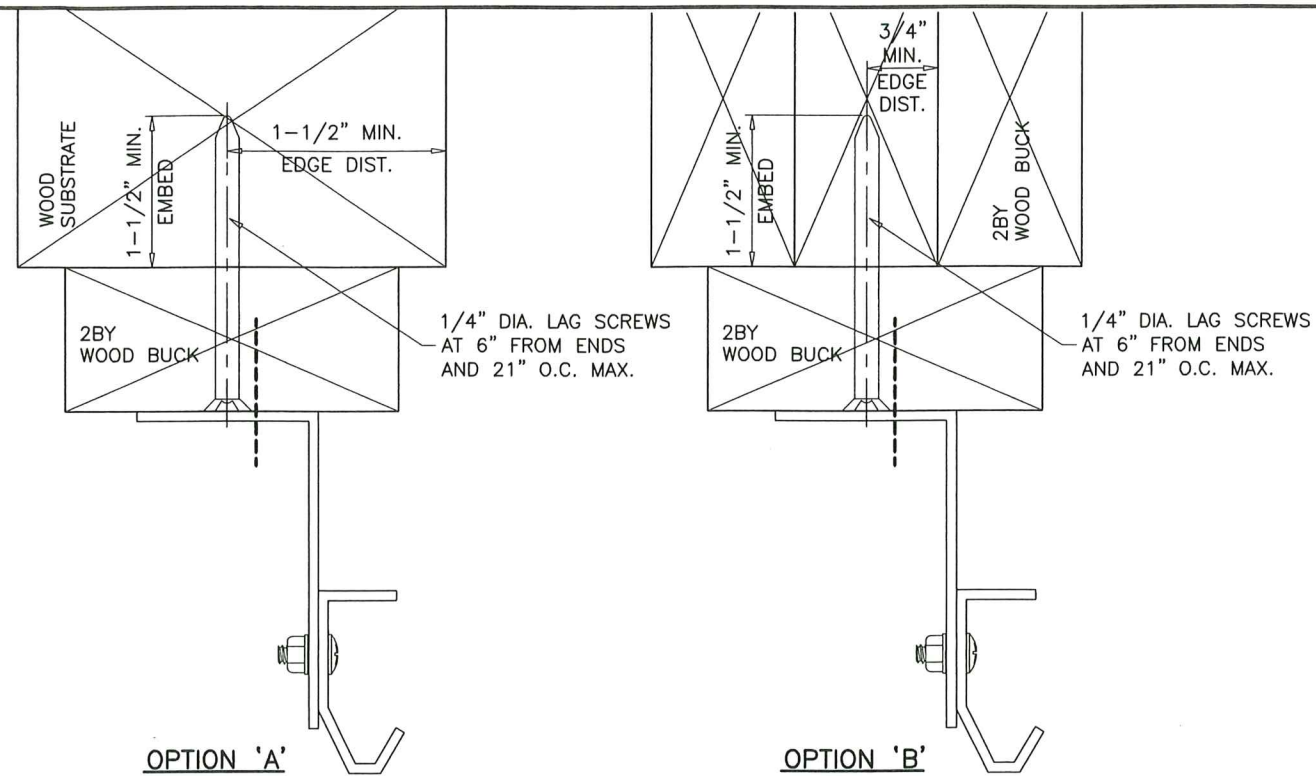

OPTION 'A'

OPTION 'B'

WOOD BUCK CONNECTION TO WOOD SUBSTRATE (WOOD SPECIFIC GRAVITY SG=0.55 MIN.)

THE INSTALLATION METHODS SHOWN ABOVE SHOWS 2X6 SYP WOOD BUCK ATTACHMENT TO WOOD STRUCTURES. IF THESE METHODS ARE FOLLOWED NO ADDITIONAL CALCULATIONS/DESIGN WILL BE REQUIRED FOR DESIGN OF GARAGE DOOR ANCHORAGE. FOR DOOR REPLACEMENT APPLICATIONS WITH NO ENGINEER OF RECORD, INSTALLATION MAY BE VERIFIED AND APPROVED BY THE BUILDING OFFICIAL UPON INSPECTION.

WOOD BUCK CONNECTION TO MASONRY

PRESSURE TREATED 2X6 SYP WOOD JAMBS WHICH SHALL BE ANCHORED TO GROUTED REINFORCED MASONRY BLOCK WALL OR CONC. COLUMN WITH

1/4" ULTRACON+ BY 'DEWALT' WITH SPACING OF 14" O.C. INTO GROUT FILLED BLOCK WALL, WITH 2-1/4" MIN. EMBED 16" O.C. INTO 3000 PSI CONCRETE, WITH 1-3/4" MIN. EMBED 2-1/2" MIN. EDGE DISTANCE

1/4" TAPPER BY 'DEWALT' WITH SPACING OF 10" O.C. INTO GROUT FILLED BLOCK WALL, WITH 1-1/2" MIN. EMBED 12" O.C. INTO 3000 PSI CONCRETE, WITH 1-3/4" MIN. EMBED 3" MIN. EDGE DISTANCE

3/8" CONFLX BY 'ELCO' OR 3/8" LDT BY 'ITW' WITH SPACING OF 24" O.C. INTO 3000 PSI CONCRETE, WITH 2-1/2" MIN. EMBED 3" MIN. EDGE DISTANCE

3/8" HLC SLEEVE BY 'HILTI' WITH SPACING OF 6" O.C. INTO GROUT FILLED BLOCK WALL, WITH 1-1/2" MIN. EMBED, 4" MIN. EDGE DIST. 16" O.C. INTO 3000 PSI CONCRETE, WITH 1-1/4" MIN. EMBED AND 2-1/2" MIN. EDGE DISTANCE

PREPARATION OF JAMBS BY OTHERS

FOR NEW CONSTRUCTION ENGINEER OF RECORD OR ARCHITECT TO VERIFY ADEQUACY OF SUPPORTING STRUCTURE TO SUPPORT LOADS IMPOSED BY DOOR SYSTEM.

FOR DOOR REPLACEMENT IN RETROFIT BUILDINGS WITH NO ENGINEER OF RECORD, DOOR INSTALLATION MAY BE REVIEWED AND APPROVED BY BUILDING OFFICIAL UPON INSPECTION.

MAXIMUM EXTERIOR(+) LOAD PER JAMB = (16.16' X 27 PSF)/2 = 218.2 Lbs per Ft.
 MAXIMUM INTERIOR(-) LOAD PER JAMB = (16.16' X 30 PSF)/2 = 242.4 Lbs per Ft.

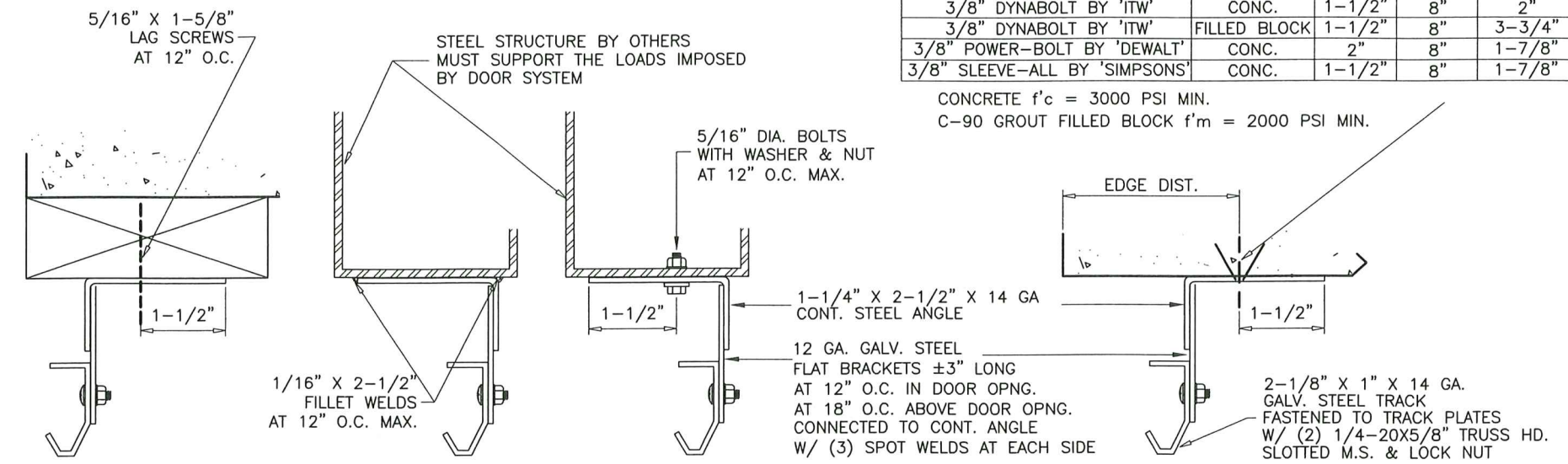

CONTINUOUS ANGLE TRACK TO WOOD BUCK

REVERSE TRACK TO STEEL

CONTINUOUS ANGLE TRACK TO CONCRETE AND FILLED BLOCK

ALTERNATE TRACK INSTALLATION

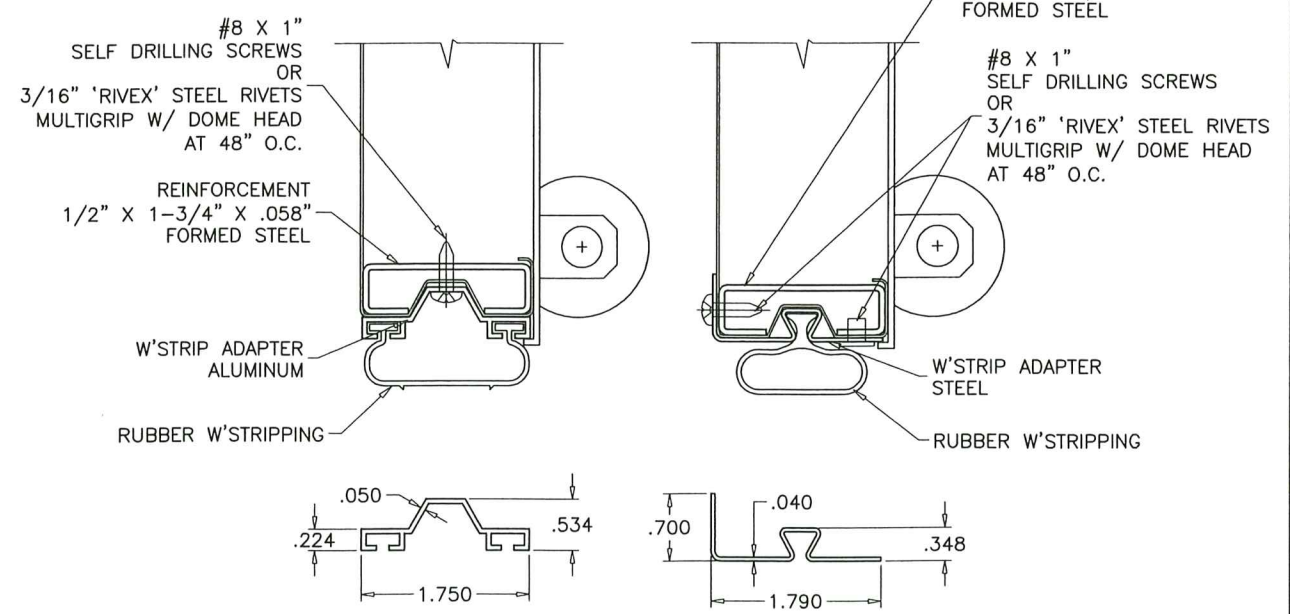

BOTTOM SEAL OPTIONS

ANCHOR SPACING				
ANCHORS	STRUCTURE	EMBED	SPACING	EDGE DIST.
3/8" HLC SLEEVE BY 'HILTI'	CONC.	1-1/4"	8"	1-5/8"
3/8" HLC SLEEVE BY 'HILTI'	FILLED BLOCK	1-1/4"	8"	4"
3/8" DYNABOLT BY 'ITW'	CONC.	1-1/2"	8"	2"
3/8" DYNABOLT BY 'ITW'	FILLED BLOCK	1-1/2"	8"	3-3/4"
3/8" POWER-BOLT BY 'DEWALT'	CONC.	2"	8"	1-7/8"
3/8" SLEEVE-ALL BY 'SIMPSONS'	CONC.	1-1/2"	8"	1-7/8"

CONCRETE f'c = 3000 PSI MIN.
 C-90 GROUT FILLED BLOCK f'm = 2000 PSI MIN.

PRODUCT REVISED as complying with the Florida Building Code Acceptance No. 23-0710-20 Expiration Date 11 AUG 2026 By H. G. A. [Signature] Miami Dade Product Control

JUN 22 2023

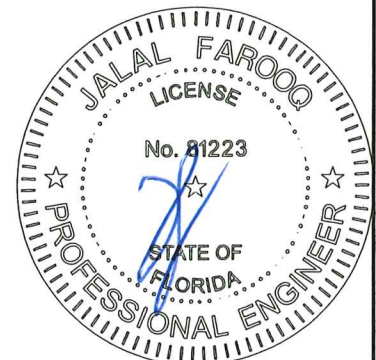

AL-FAROOQ CORPORATION
 ENGINEERS & PRODUCT DEVELOPMENT
 9360 SUNSET DRIVE, SUITE 220
 MIAMI, FLORIDA 33173
 TEL. (305) 264-8100 FAX. (305) 262-6978

SECTIONAL GARAGE DOOR
DAB Door Company, Inc.
 12193 N.W. 98th Ave.
 Hialeah Gardens, Fl. 33018
 Tel: (800) 257-2016 Fax: (305) 362-9272

no	date	by	description
L	08.02.17		UPDATED TO 2017 FBC
M	07.21.20		UPDATED TO 2020 FBC
N	08.12.22		GENERAL REVISION
O	06.19.23		NO CHANGE THIS SHEET

date: 09-30-03
 scale: -
 dr. by: TARIQ
 chk. by:

drawing no.
03-06
 sheet 4 of 6

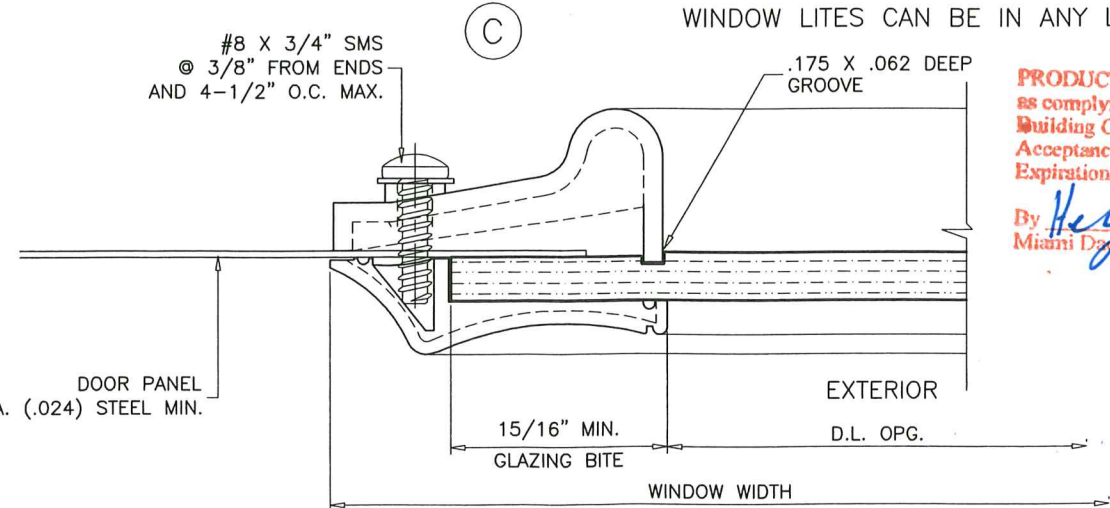
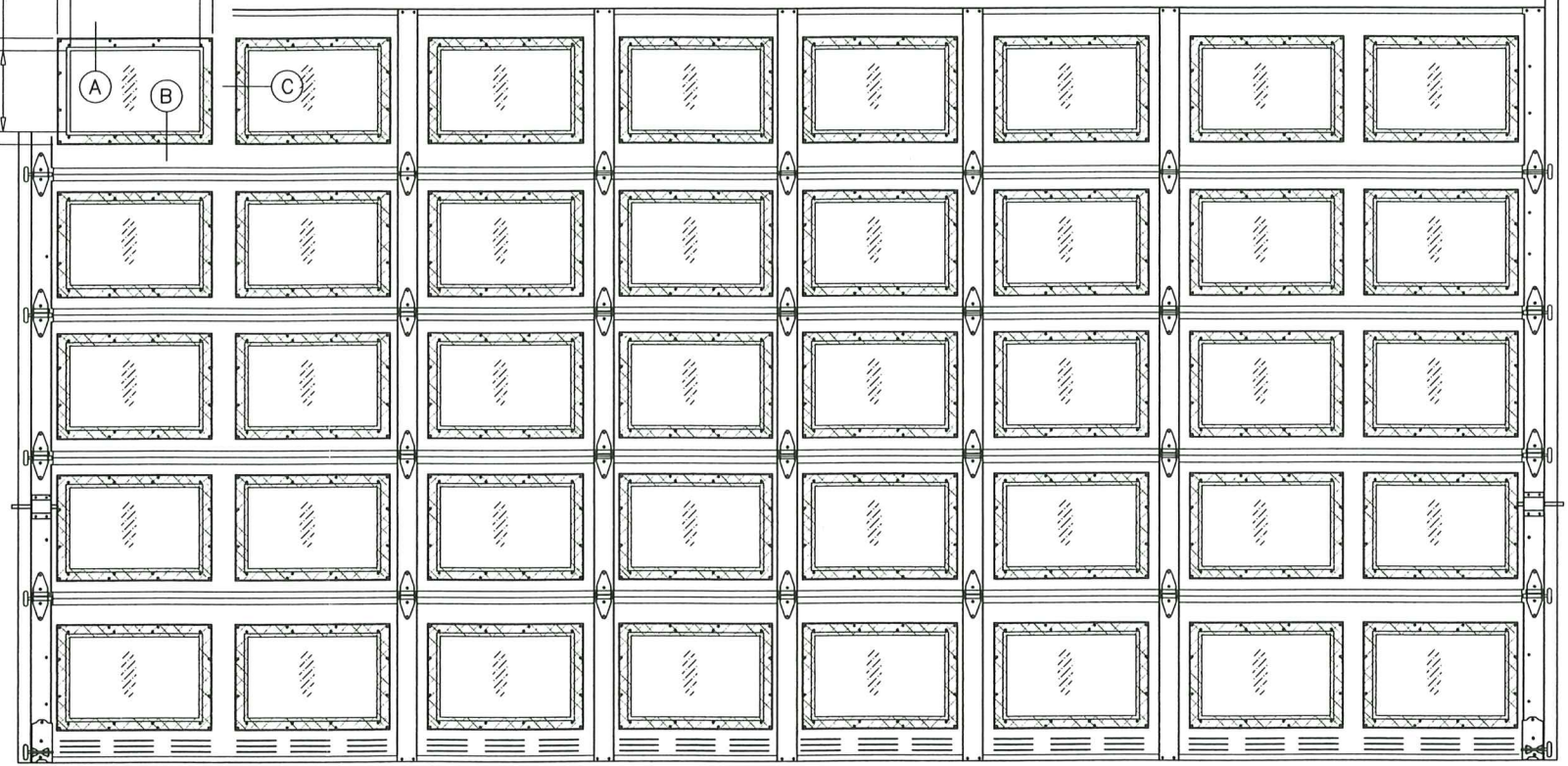
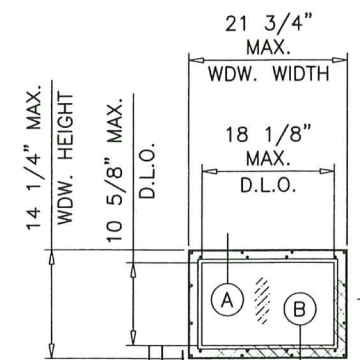
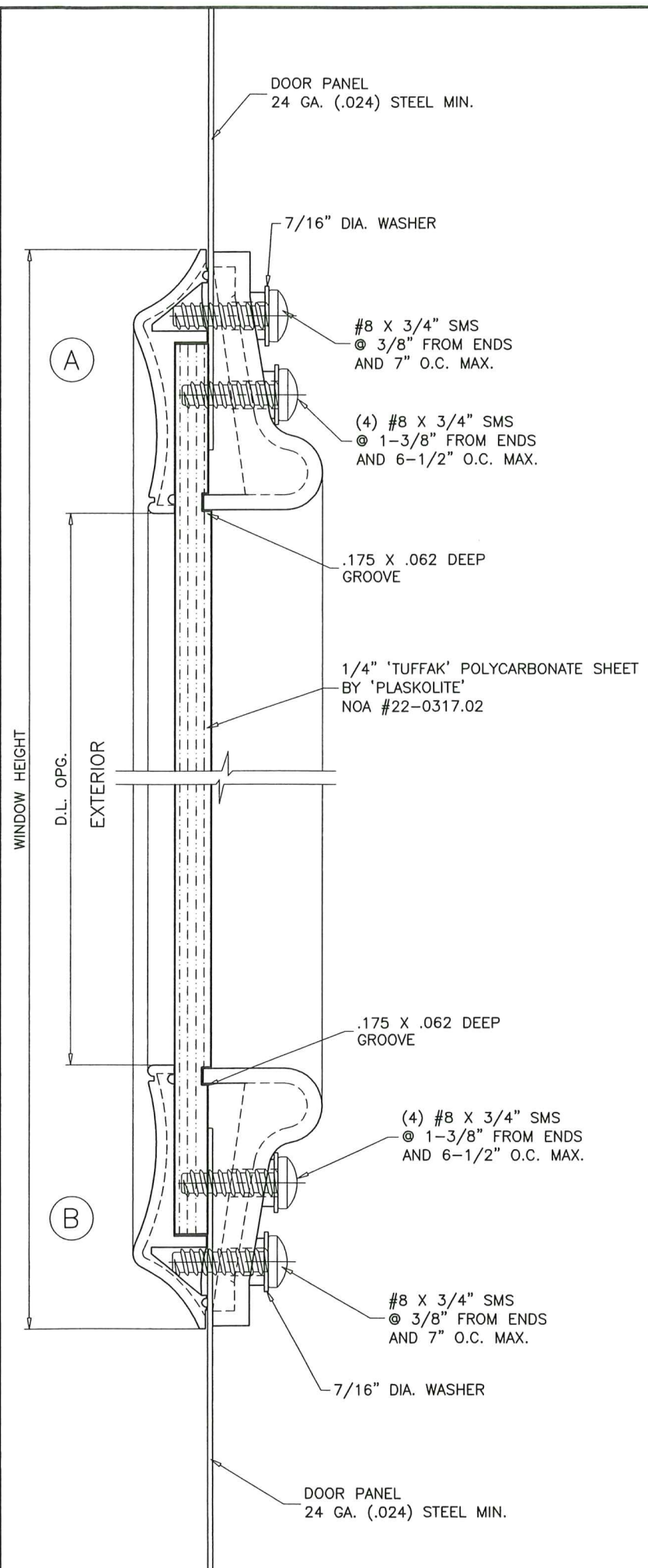

* PLASTIC COMPLIES WITH
CHAPTER 26 OF FBC
SEE EVIDENCE PAGE

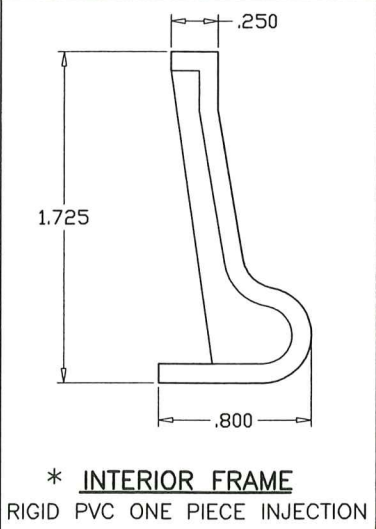
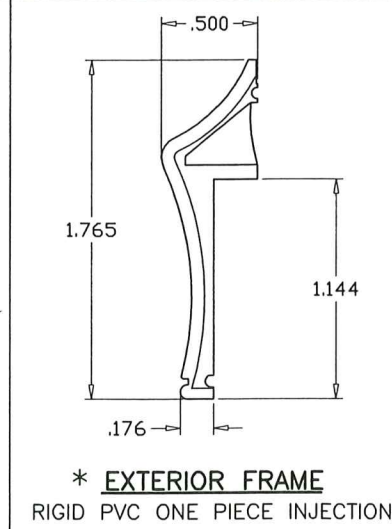

PRODUCT REVISED
as complying with the Florida
Building Code 23-0710.20
Acceptance No
Expiration Date 14 AUG 2026

By *Hegda*
Miami Door Product Control

JUN 22 2023

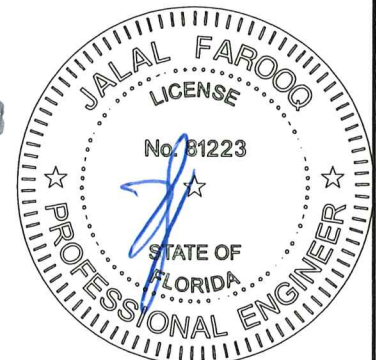

AL-FAROOQ CORPORATION
ENGINEERS & PRODUCT DEVELOPMENT
9360 SUNSET DRIVE, SUITE 220
MIAMI, FLORIDA 33173 (C.A.N. 3538)
TEL. (305) 264-8100 FAX. (305) 262-6978
GARAGE\03-06DAB

SECTIONAL GARAGE DOOR
DAB Door Company, Inc.
12193 N.W. 98th Ave.
Hialeah Gardens, Fl. 33018
Tel: (800) 257-2016 Fax: (305) 362-9272

no	date	by	description
L	08.02.17		UPDATED TO 2017 FBC
M	07.21.20		UPDATED TO 2020 FBC
N	08.12.22		GENERAL REVISION
O	06.19.23		NO CHANGE THIS SHEET

date: 09-30-03
scale: -
dr. by: TARIQ
chk. by:

drawing no.
03-06
sheet 5 of 6

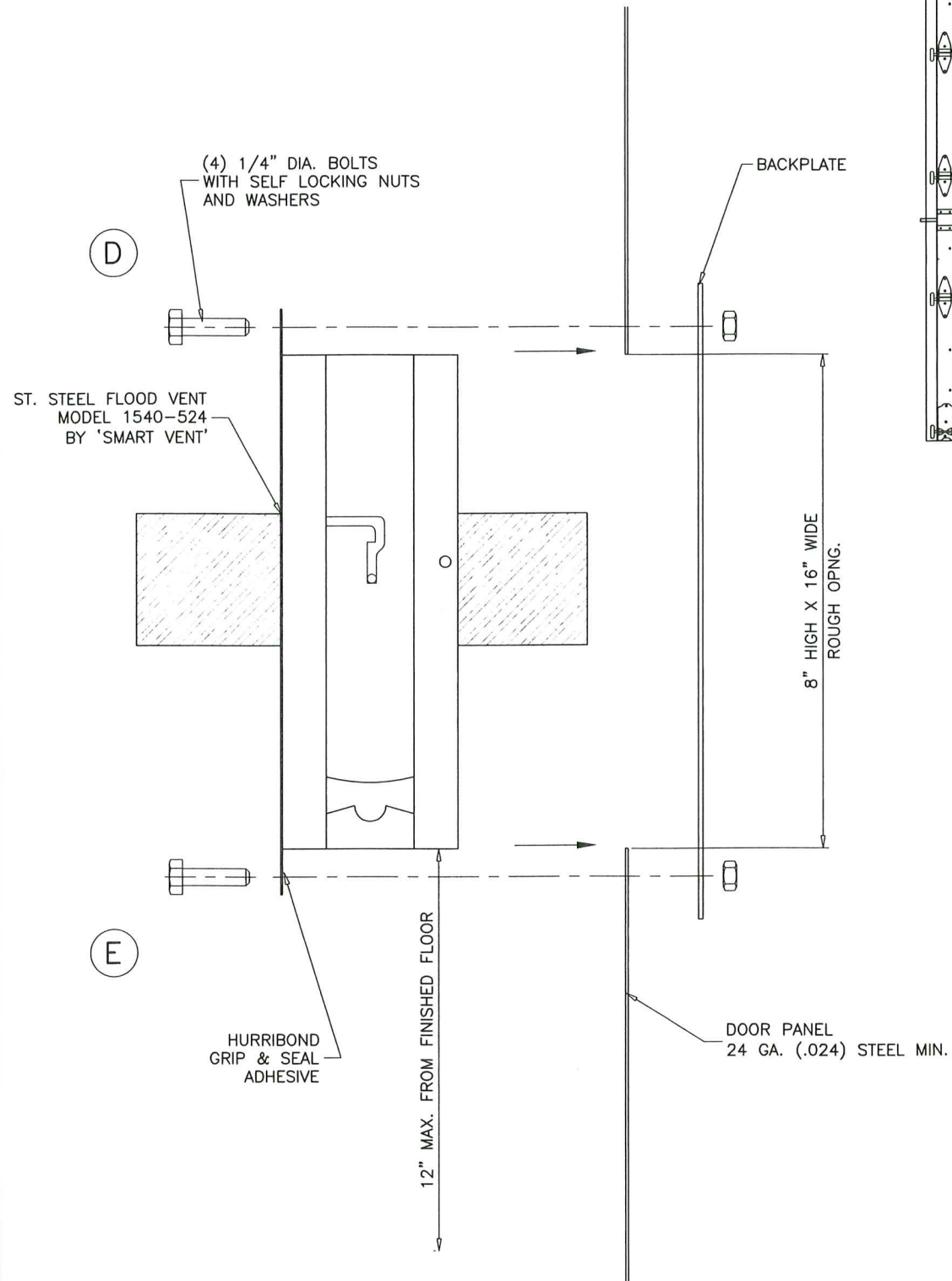

FLOOD VENT DETAIL
AUTOMATIC NON-POWERED ACTIVATION & OPERATION

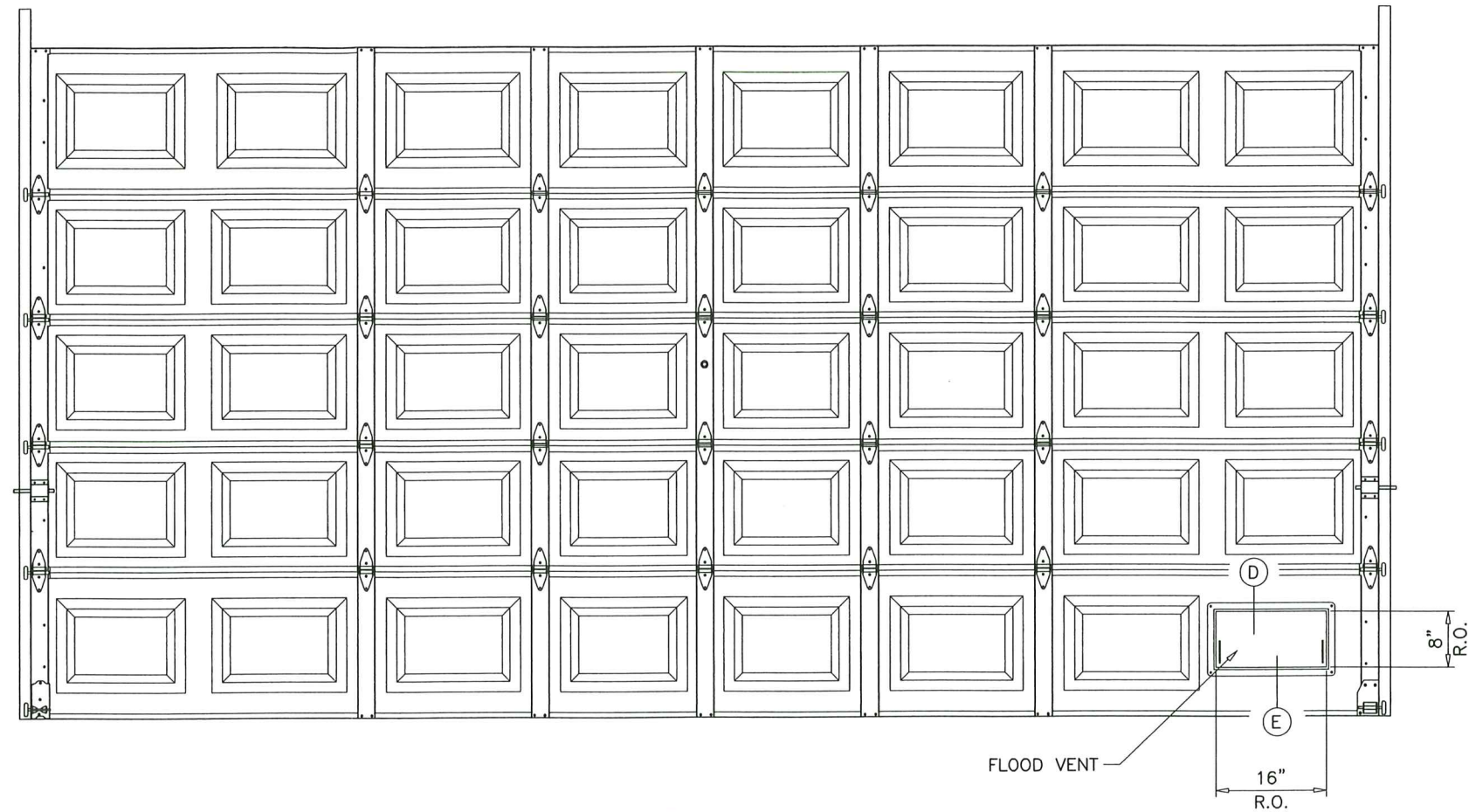

INSIDE ELEVATION

RAISED PANEL EMBOSSED DOOR WITH OPTIONAL FLOOD VENT
FLOOD VENT CAN BE IN ANY LOCATION IN BOTTOM SECTION

GARAGE DOOR WITH FLOOD VENT NOT RATED FOR LARGE MISSILE IMPACT.
INSTALLATION OF THIS DOOR IN THE HVHZ AREA REQUIRES THE USE OF APPROVED EXTERNAL PROTECTION DEVICES COMPLYING WITH HVHZ REQUIREMENTS.
INSTALLATION OF THIS DOOR OUTSIDE THE HVHZ AREA SHALL MEET THE APPLICABLE REQUIREMENTS FOR WIND BORNE DEBRIS PROTECTION.

PRODUCT REVISED
as complying with the Florida
Building Code **23-0710-20**
Acceptance No
Expiration Date **14 AUG 2026**
By *Helya Mahabadi*
Miami Door Product Co.

JUN 22 2023

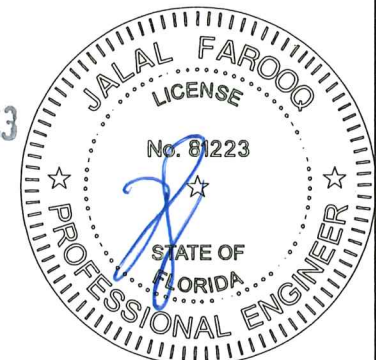

af c
AL-FAROOQ CORPORATION
ENGINEERS & PRODUCT DEVELOPMENT
9360 SUNSET DRIVE, SUITE 220
MIAMI, FLORIDA 33173 (C.A.N. 3588)
TEL. (305) 264-8100 FAX. (305) 262-6978
GARAGE\03-06DAB

SECTIONAL GARAGE DOOR
DAB Door Company, Inc.
12193 N.W. 98th Ave.
Hialeah Gardens, Fl. 33018
Tel: (800) 257-2016 Fax: (305) 362-9272

no	date	by	description
N	08.12.22		GENERAL REVISION
O	06.19.23		NO CHANGE THIS SHEET

date: 09-30-03
scale: 1/2" = 1"
dr. by: TARIQ
chk. by:

drawing no.
03-06
sheet 6 of 6